

32"-55" FLAT SCREEN TILT/SWIVEL WALL MOUNT BRACKET

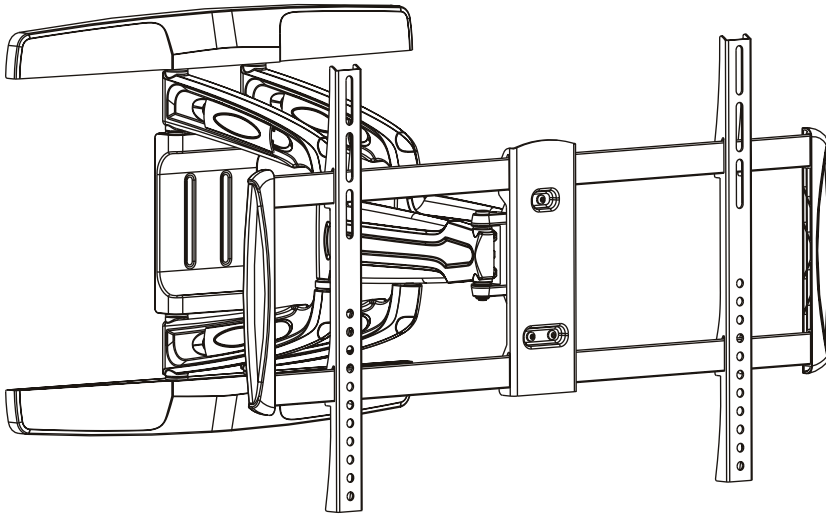

650314



200x200/300x300
400x200/400x400



INSTALLATION MANUAL

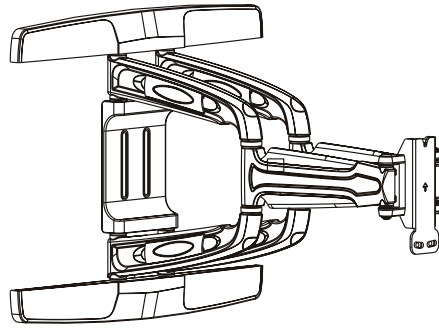
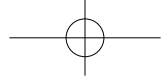

wall mount (x1)
A

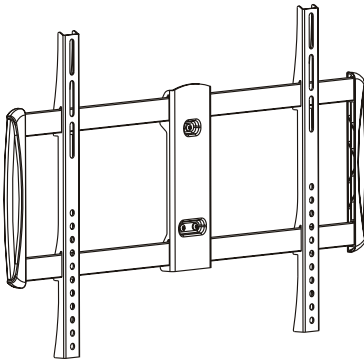

universal plate (x1)
B

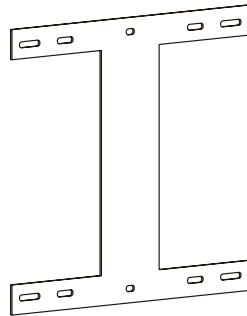

template (x1)
C



3mm Allen key (x1)
D



4mm Allen key (x1)
E



wrench (x1)
F

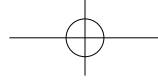

Package M



M5x14 (x4)
M-A

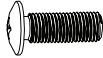

M6x14 (x4)
M-B



M8x20 (x4)
M-C



M6x30 (x4)
M-D



M8x30 (x4)
M-E



washer (x4)
M-F



small spacer (x8)
M-G



big spacer (x4)
M-H

Package W



ST6.3x55 (x6)
W-A

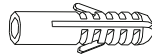

concrete anchor (x6)
W-B



D6 washer (x6)
W-C

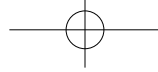

1.

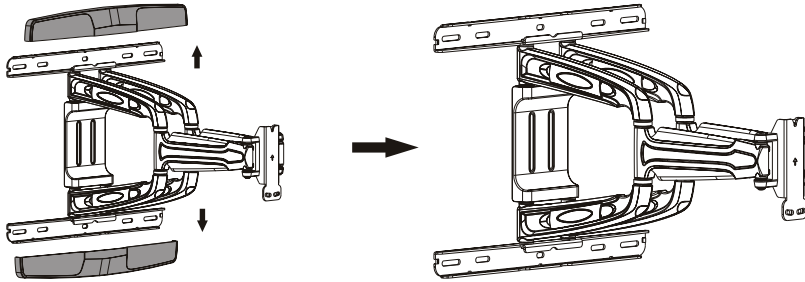

2-A. for wood stud wall mounting

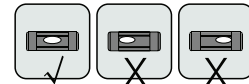
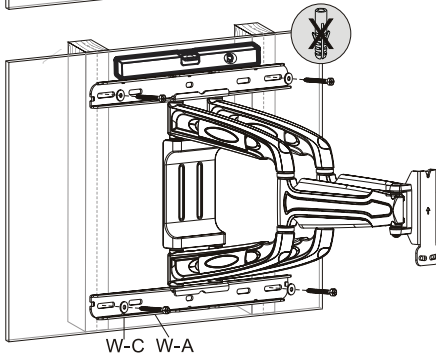
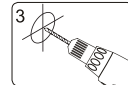
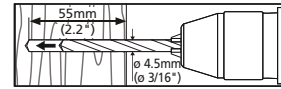
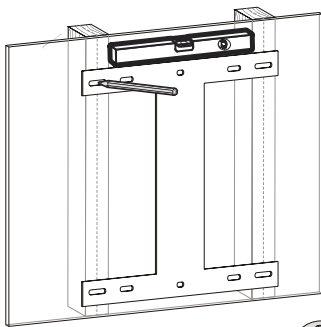
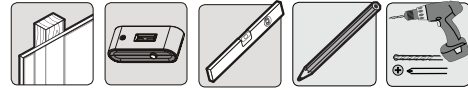

Stud	406mm (16")	450mm (17.7")	600mm (23.6")	610mm (24")
Model:650314	v	v	x	x

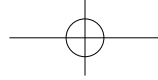

2-B. for solid brick and concrete mounting

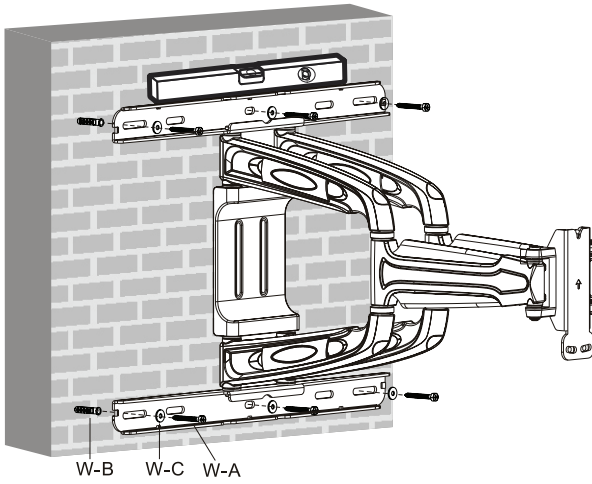
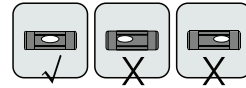
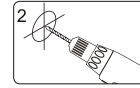
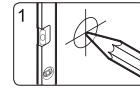
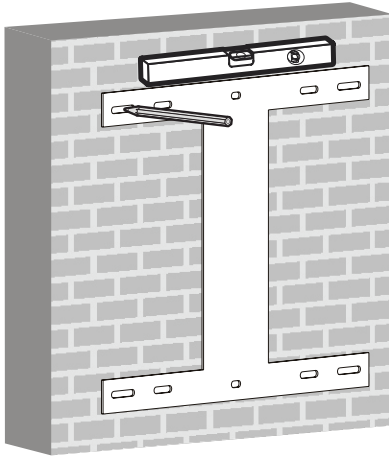
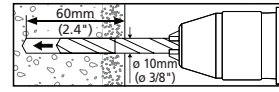
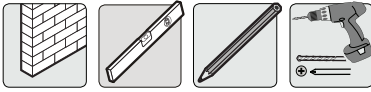

W-B W-C W-A

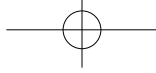

3.

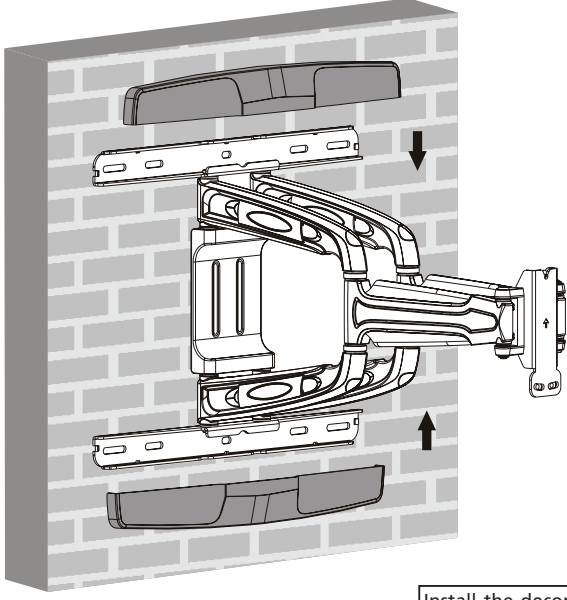

Install the decorative covers along the wall plate rail until they fit snugly onto the wall plate.

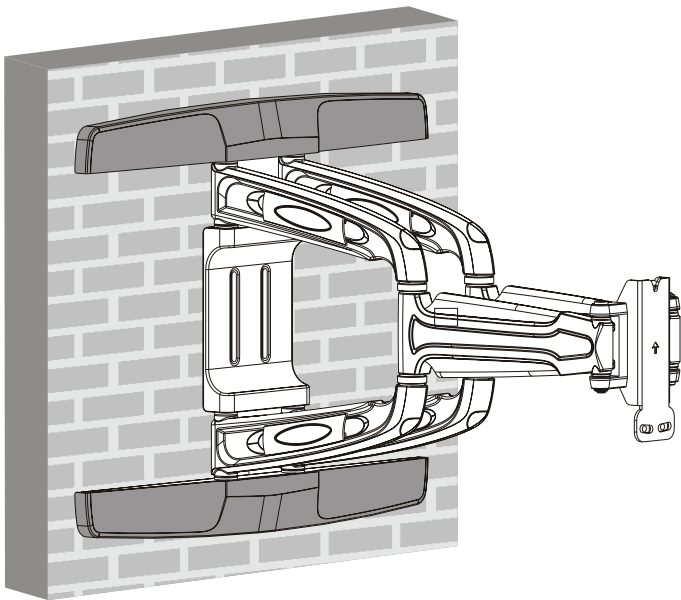



4.

Remove the both bottom nuts.

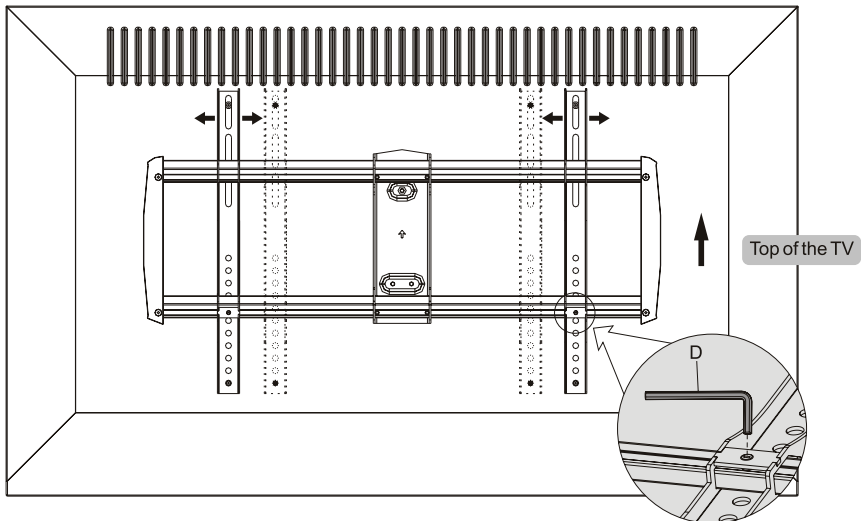
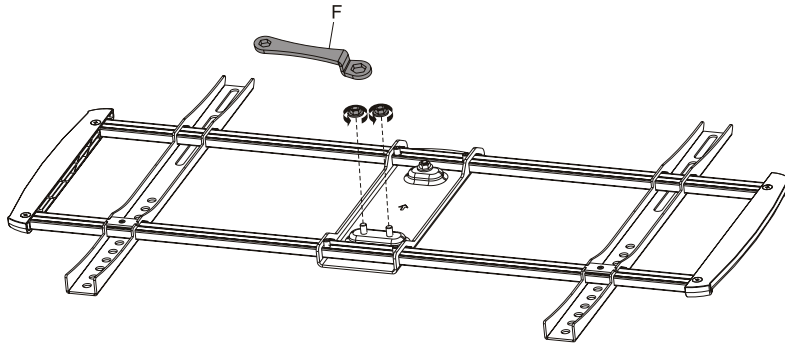

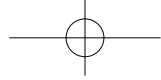

4-1. for flat back screens

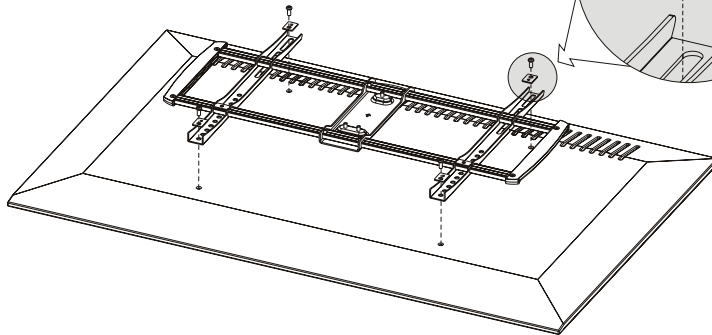
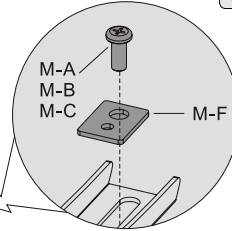
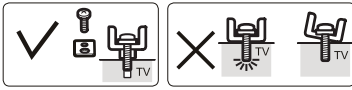

4-2. for recessed back screens or to access A/V inputs

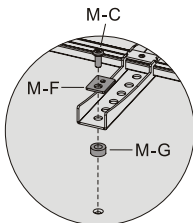
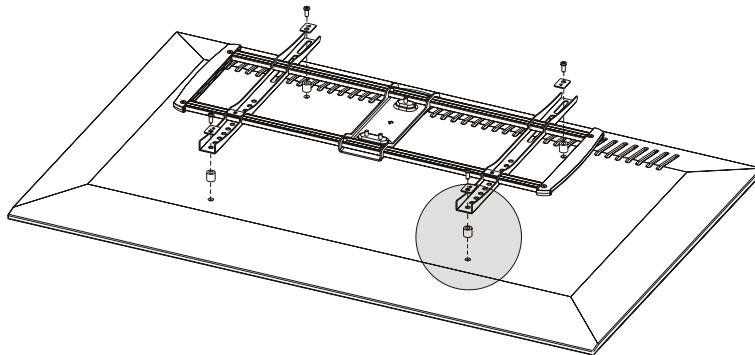

or

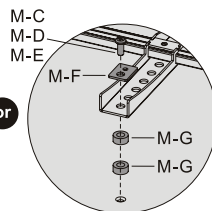

or

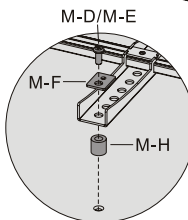

or

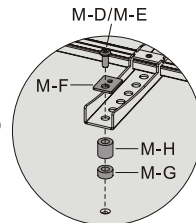

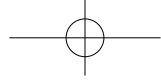

5.

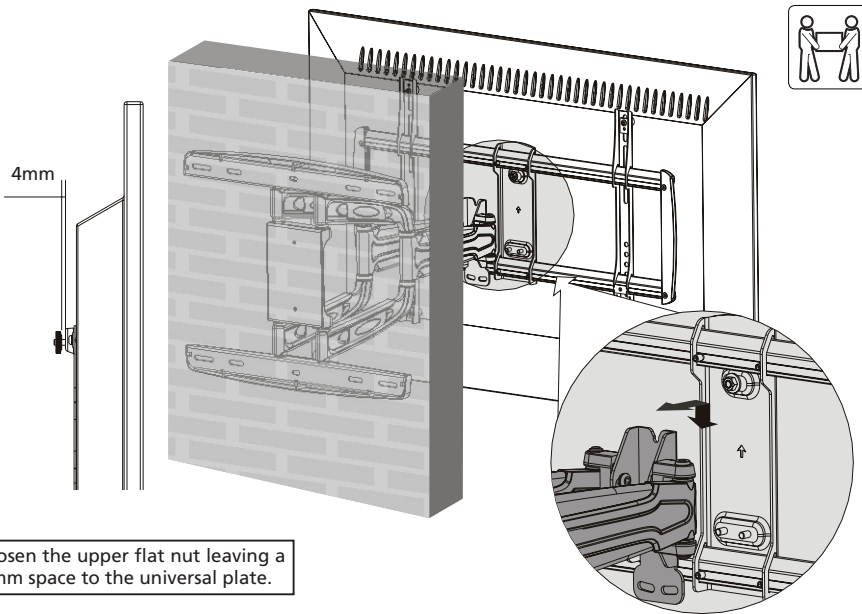

loosen the upper flat nut leaving a 4mm space to the universal plate.

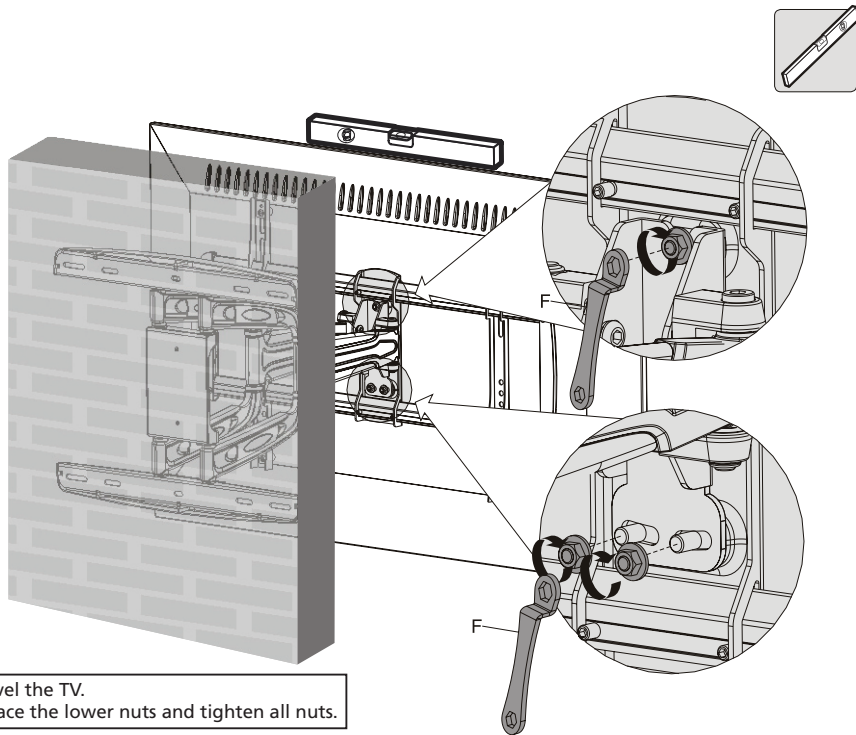

- level the TV.
- place the lower nuts and tighten all nuts.

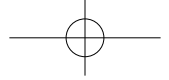

6.

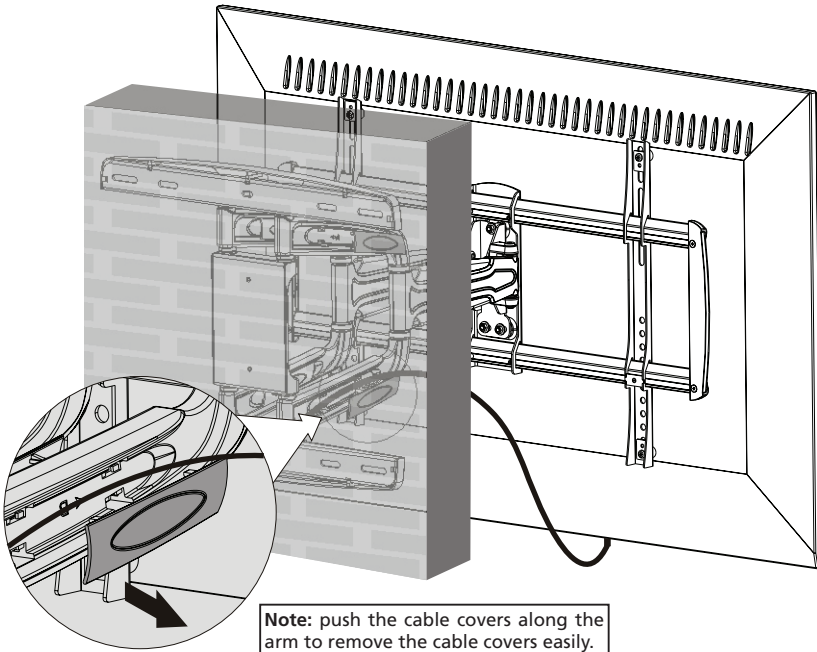

Note: push the cable covers along the arm to remove the cable covers easily.

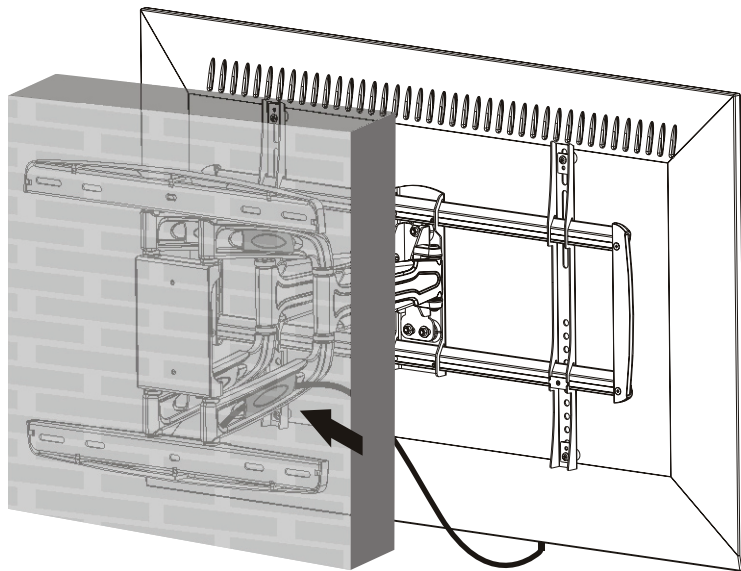

remove the cable covers to run the cables.
re-attach the cable covers to hold the cable in place.
Note: - leave slack in the cable for arm movement.
- route the power cable and the signal cable in different cable covers to avoid signal disturbance.

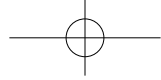

7.

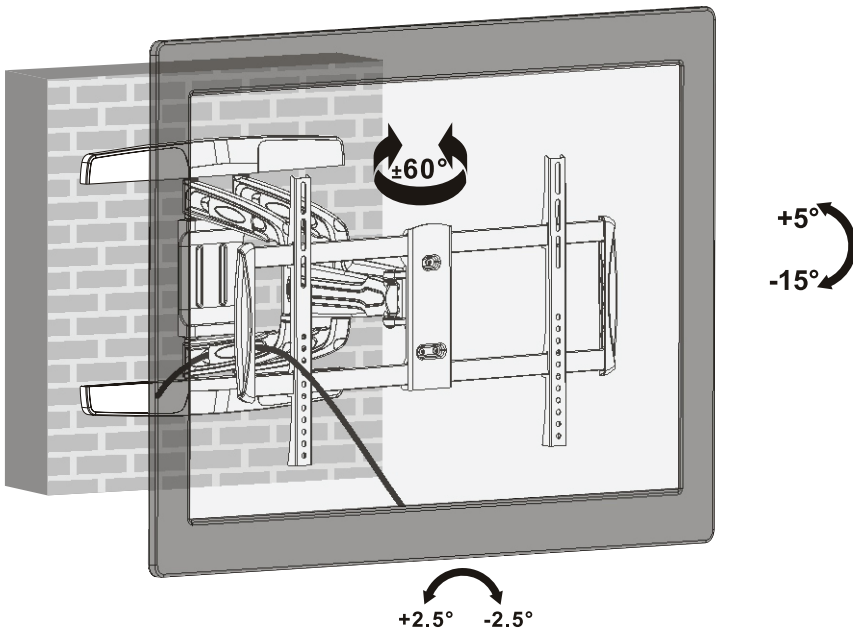
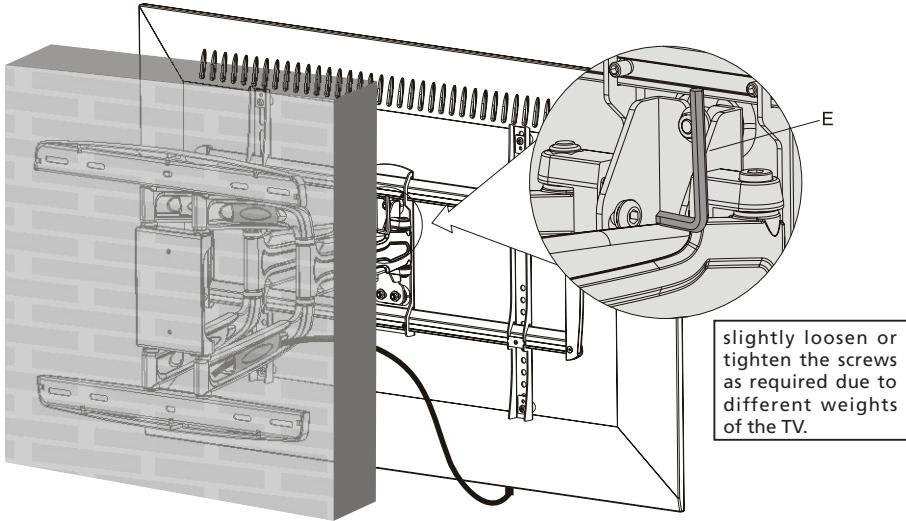



EN Read the entire instruction manual before you start installation and assembly. If you have any questions regarding any of the instructions or warnings, please contact your local distributor for assistance.



- CAUTION:** Use with products heavier than the rated weights indicated may result in instability causing possible injury.
- Mounts must be attached as specified in assembly instructions. Improper installation may result in damage or serious personal injury.
 - Safety gear and proper tools must be used. This product should only be installed by professionals.
 - This product is designed to be installed on wood stud walls, solid concrete walls or brick walls.
 - Make sure that the supporting surface will safely support the combined weight of the equipment and all attached hardware and components.
 - Use the mounting screws provided and DO NOT OVER-TIGHTEN mounting screws
 - This product contains small items that could be a choking hazard if swallowed. Keep these items away from children.
 - This product is intended for indoor use only. Using this product outdoors could lead to product failure and personal injury.

IMPORTANT: Ensure that you have received all parts according to the component checklist prior to installation. If any parts are missing or faulty, telephone your local distributor for a replacement.

MAINTENANCE: Check that the bracket is secure and safe to use at regular intervals (at least every three months).

GE Bitte vor Beginn der Montage und Zusammenbau das ganze Handbuch durchlesen. Bitte sich mit dem Händler vor Ort bei Fragen zur Anleitung oder Warnungen in Verbindung setzen.



- VORSICHT:** Bei Verwendung mit Produkten, die das zulässige Gewicht überschreiten, können Schäden oder möglicherweise Verletzungen die Folge sein.
- Hallerungen sollen entsprechend den Montageanweisungen angebracht werden. Eine unsachgemäße Montage kann Schäden oder Verletzungen zur Folge haben.
 - Sicherheitsausrüstung und geeignete Werkzeuge verwenden. Die Montage des Produktes sollte nur von Fachleuten durchgeführt werden.
 - Dieses Produkt kann auf Wänden mit Fachwerk, massiven Beton- oder Steinwänden montiert werden.
 - Die tragenden Oberflächen sollten das gesamte Gewicht von Geräten und allen zusätzlichen Bauteilen sicher aushalten können.
 - Nur die mitgelieferten Einbauschrauben verwenden und die Schrauben NICHT ZU FEST ANZIEHEN.
 - Dieses Produkt enthält Kleinteile, die Erstickungsgefahr beim Verschlucken hervorrufen können. Diese Teile von Kindern fernhalten.
 - Dieses Produkt nur in Innenräumen verwenden. Verwendung des Produktes im Außenbereich kann zu Verletzungen und Schäden führen.

WICHTIG: Vor der Montage bitte alle erhaltenen Bauteile mit der Bauteilleiste abgleichen. Bei beschädigten oder fehlenden Teilen den Händler vor Ort nach Ersatzteilen fragen.

WARTUNG: Die Halterungsklammer regelmäßig auf Sicherheit und Stabilität prüfen (am besten alle drei Monate).

FR Lisez entièrement le guide d'utilisateur avant de commencer l'installation et le montage. Si vous avez des questions concernant les instructions ou les avertissements, veuillez contacter votre distributeur local pour une assistance.



- ATTENTION:** L'usage de produits, plus lourds que les poids nominaux indiqués peut entraîner une instabilité causant des blessures potentielles.
- Les supports doivent être joints comme spécifié dans les instructions de montage. Une mauvaise installation peut entraîner des dommages ou de graves blessures aux personnes.
 - Un équipement de sécurité et les outils appropriés doivent être utilisés. Ce produit devrait être installé uniquement par des professionnels.
 - Ce produit est conçu pour être installé sur des murs avec poteaux en bois, des murs en béton massif ou murs en brique.
 - Assurez-vous que la surface de soutien supporte en sécurité le poids combiné de l'équipement et de tous les matériaux et composants associés.
 - Utilisez les vis de montage fournies et NE SERREZ PAS TROP les vis de montage
 - Ce produit contient de petites pièces qui peuvent causer un étouffement si elles sont avalées. Éloignez ces pièces des enfants.
 - Ce produit est prévu uniquement pour une utilisation à l'intérieur. L'utilisation de ce produit à l'extérieur peut entraîner une défaillance du produit ou des blessures aux personnes.

IMPORTANT: Avant l'installation, assurez-vous que vous avez reçu toutes les pièces selon la liste de vérification des composants. Si une pièce est manquante ou endommagée, téléphonez à votre distributeur local pour qu'il la remplace.

MAINTENANCE: A intervalles réguliers (au moins tous les trois mois) vérifiez que le support est d'utilisation sûre et fiable

RU Перед началом установки и сборки прочитайте руководство по установке. Если у Вас возникли какие-либо вопросы относительно инструкции или предупреждений, свяжитесь с Вашим местным распространителем для получения помощи.



- Внимание:** Использование продуктов, вес которых превышает указанный расчетный вес, может привести к нестабильности и возможному повреждению.
- Опоры должны быть установлены, как это показано в монтажных инструкциях. Неправильная установка может привести к повреждению продукта и получению серьезных травм.
 - Необходимо использовать предохранительное устройство и специальные инструменты. Продукт должен устанавливаться только профессионалами.
 - Продукт предназначен для установки на деревянные каркасные стены, твердые цементные стены или кирпичные стены.
 - Убедитесь, что несущая поверхность выдержит вес оборудования и всего установленного оборудования и комплектующих.
 - Необходимо использовать идущие в комплекте установочные шурупы и НЕ ПЕРЕТЯГИВАТЬ установочные шурупы
 - Данный продукт содержит маленькие детали, которые представляют опасность удушья при проглатывании. Такие детали необходимо хранить в недоступном для детей месте.
 - Данный продукт предназначен только для эксплуатации в помещениях. Использование данного продукта на улице может привести к поломке продукта и получению травм.
- ВАЖНО:** Перед установкой убедитесь, что Вы получили все детали в соответствии со списком комплектующих. Если не хватает каких-либо деталей или они поломаны, свяжитесь с Вашим местным распространителем по вопросу замены.

ТЕХНИЧЕСКОЕ ОБСЛУЖИВАНИЕ: Необходимо регулярно проверять (как минимум, раз в три месяца), чтобы кронштейн был зафиксирован, и его использование было безопасным.

SP Lea todo el manual de instrucciones antes de comenzar la instalación y ensamble de la unidad. Si tiene alguna inquietud con respecto a las instrucciones o advertencias, comuníquese con su distribuidor local.



- PRECAUCIÓN:** utilizar con productos de mayor peso al indicado en los límites de peso podría ocasionar inestabilidad y posibles heridas personales.
- Los soportes deben acoplarse tal como se indica en las instrucciones de ensamble. Una incorrecta instalación podría ocasionar daños y serias heridas personales.
 - Utilice las herramientas y equipo de seguridad adecuados. Este producto solo debe ser instalado por profesionales.
 - Este producto está diseñado para instalaciones en paredes de madera sólida, concreto sólido o bloques.
 - Asegúrese de que la superficie de fijación sostenga de manera segura el peso total del equipo y todos sus componentes y hardware.
 - Utilice los tornillos de ensamble suministrados y NO aplique demasiada tensión a los tornillos.
 - Este producto contiene piezas pequeñas que representan un riesgo de asfixia. Mantenga estas piezas fuera del alcance de los niños.
 - Este producto está diseñado para uso en interiores solamente. Utilizar este producto en exteriores podría ocasionar fallas y heridas personales.
- IMPORTANTE:** Asegúrese de que haya recibido todas las piezas según la lista de verificación de componentes para la instalación. Si falta alguna de las partes, o está dañada, comuníquese con su distribuidor.

MANUTENIMIENTO: Compruebe periódicamente que el soporte esté asegurado y listo para usar (al menos cada tres meses).

POR Leia todo o manual de instruções antes de iniciar a instalação e montagem. Se você tiver alguma dúvida sobre quaisquer uma das instruções ou avisos, por favor, entre em contato com o seu distribuidor local para assistência.



- ATENÇÃO:** O uso com produtos mais pesados do que os pesos indicados pode resultar em instabilidade, causando possíveis danos.
- Os suportes devem ser anexados como especificado nas instruções de montagem. A instalação incorreta pode causar danos ou sérias lesões pessoais.
 - Equipamentos de segurança e ferramentas adequadas devem ser utilizadas. Este produto só deve ser instalado por profissionais.
 - Este produto é projetado para ser instalado em pilares verticais de paredes de madeira, paredes de concreto sólido ou de tijolos.
 - Certifique-se que a superfície de suporte suportará com segurança o peso combinado do equipamento e todas as ferragens e componentes anexados.
 - Use os parafusos de montagem fornecidos e NÃO APERTE EXCESSIVAMENTE os mesmos.
 - Este produto contém pequenas peças que podem causar asfixia se ingeridas. Mantenha esses itens longe do alcance de crianças.
 - Este produto destina-se somente para uso interno. Usá-lo em ambiente externo pode causar falhas no produto e lesões pessoais.
- IMPORTANTE:** Asegure-se que você recebeu todas as peças, de acordo com a lista de componentes, antes da instalação. Se alguma peça estiver faltando ou é defeituosa, contate o seu distribuidor local para substituição.

MANUTENÇÃO: Certifique-se que o suporte seja seguro e protegido para o uso em intervalos regulares (pelo menos a cada três meses).